

1. SPECIFICATIONS:

Liquid Applicable Viscosity Range {cP(mPa*s)}	50-3500 (50-3500)
Soap Type	Pure Liquid, no grit or abrasive content, undiluted or gel hand sanitizer
pH Range	7 ± 1.5
Operation Mode	Automatic from Sensor Trigger
Supply Reservoir (Soap Tank) Type	Removable, Latching Rigid PE, screw on cap, check valve
Soap Tank Capacity {fl oz (ml)}	34 (1000)
Battery Type Required	Alkaline (1.5 V) Size AA, Qty 6; Provided By Others (*)
Battery Life Estimated	10,000 cycles or 1 year
Detection Range Automatic {inches [mm]}	3-1/8" [80] ± 3/8" [10]
Room Temperature Ambient {°F (°C)}	41 ~ 104 (5 ~ 40)
Sensing Delay Time (second)	0.50 ~ 1.50
Pump Type	Roller-wheel metering pump-motor w/ no-drip jog
Volume Dispensed {fl oz (ml)}	0.03 ± 0.002 (0.8 ± 0.05)
Dimensions {(W x H x D) inches [mm]}	5.47 x 10.75 x 3.98 [139 x 273 x 101]
Unit Net Weight {lb (kg)}	3.3 (1.5) with batteries, without soap
Housing Material	Stainless Steel, Type 304, Alloy 18-8

2. ITEM LIST:

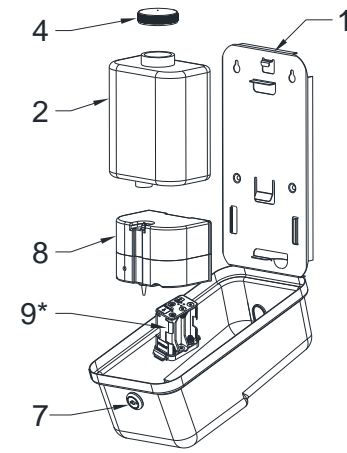

Illustration	Description	Qty	Illustration	Description	Qty
1	Soap Dispenser Housing	1	6	ASI Key E-114	1
2	Soap Tank	1	7	ASI Lock	1
3	Installation Template	1	8	Control Housing	1
4	Cap For Tank	4	9	Battery Holder	1
5	Light Pipe w/ Mounting Tape (Not Shown)	1	10	Sensor Gasket Bezel (Not Shown)	1

FIGURES ARE BEST VIEWED ONLINE FOR ENHANCED CLARITY

3. RECOMMENDED INSTALLATION REQUIREMENTS:

- 3.1 Ensure that the wall-mounting surface chosen for installation is smooth, flat, vertical and clean.
- 3.2 Ensure that the mounting position allows at least 10" [254] clearance above any surface.
- 3.3 Ensure that the mounting position allows more than 2" [51] clearance above the unit for lock access.
- 3.4 Ensure that there is no light source reflecting from the surface below the dispenser up at the sensor.

Read this important instruction sheet completely before commencing installation and retain it for future reference during lifetime of product (turn sheet over to Facility Manager if appropriate).

4. INSTALLATION STEPS

- 4.1 Tape the installation template (p/n-0902271000) to the wall at the mounting location (Fig.1).
- 4.2 Drill four (4) holes into wall to receive plastic anchors (by others).
- 4.3 Push plastic anchors (by others) into holes with heads flush with wall face.
- 4.4 Insert two (2) pan head screws (# 8 x 1-1/2 self-tapping, by others) into top two (2) plastic anchors leaving 3/8" [10] space under head to wall (Fig.2).
- 4.5 Open dispenser housing and remove the soap tank by pulling slightly forward and then up to disengage the latch-tab (Fig.3).
- 4.6 Hang dispenser housing (Fig.4) on the two (2) screws (step 4.4, above) and install two (2) flat head screws (#8 x 1-1/2 self tapping, by others) into bottom two (2) plastic anchors. Tighten all screws (Fig.5).
- 4.7 Fill the soap tank with appropriate soap and close the cap (Fig.10).
- 4.8 Remove the battery door & holder from the control module by squeezing the latch release tabs on bottom at front and back in finger notches. Install batteries into the battery holder in accordance with polarity indications (Fig. 12). Reinstall the holder (Fig's. 8 & 9). Observe polarity indication labels on battery holder. Ensure snap latches are engaged and secure.
- 4.9 Reinstall the control module onto the chassis tracks and ensure it is under the retainer latch on back plate (Fig's. 5 & 10). Reinstall the soap tank onto the control module spike connector and push back under the retainer tab on the back plate (Fig.6).
- 4.10 Close the cover and lock the dispenser (Fig.7, Fig.11).

5. SETUP STEPS

- 5.1 With completion of step 4.10 notice the LED will flash four (4) times to indicate unit is ready for operation.
- 5.2 Notice on initial setup that several operation cycles are required to fill the dry pump with soap the first time.

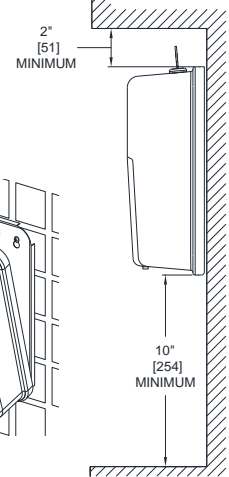
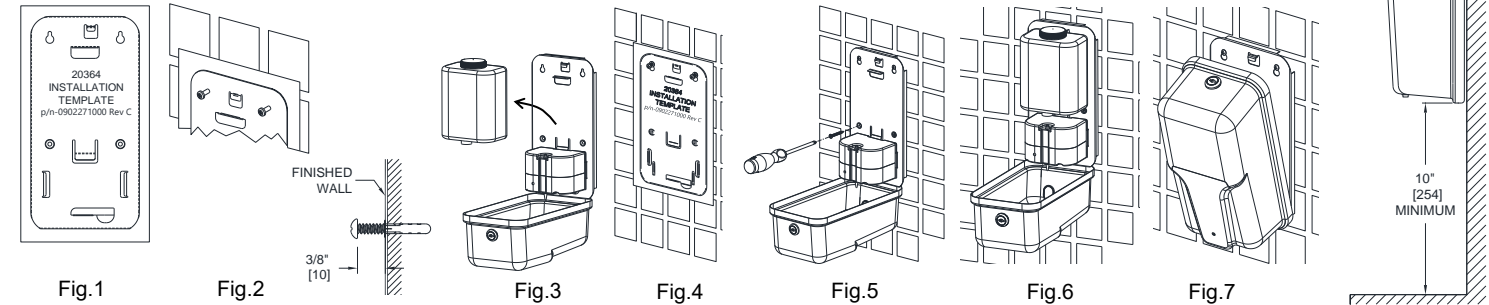

6. OPERATION & MAINTENANCE

- 6.1 Use clean soap from closed container to refill reservoir. Ensure that soap conforms to properties ranges listed above in SPECIFICATIONS and does NOT contain abrasive grits.
- 6.2 Clean soap reservoir of any soap residue on a monthly basis before refilling with fresh soap. Congealed or ossified soap deposits may lead to dispensing malfunction. Refills by "topping off" if required are OK in-between tank cleanings.
- 6.3 Clean exterior housing daily in high traffic areas and weekly in low traffic areas in cycles determined by established facility maintenance schedules. Use soft cleaning rag with Stainless Steel Cleaner & Polish (typical 3M product, others may be appropriate) and completely wipe away residue with fresh water moistened clean towel. Do not soak or submerge unit for cleaning or rinsing. Avoid directly spraying cleaners into lock, as it is difficult to remove residue from inside working parts and will ultimately lead to jamming. Do not clean under running water.
- 6.4 The sensor lens may be cleaned of splash residue by wiping with a soft clean rag lightly dampened with a general-purpose surface cleaner suitable for kitchen or washroom countertops. Avoid using abrasive materials or grit-contaminated rags as this will scratch the lens and degrade the triggering operation.
- 6.5 Replace the batteries on a regular interval depending on activity level and on cycles determined by established facility maintenance schedules.

7. TROUBLESHOOTING GUIDE:

SYMPTOM	POSSIBLE CAUSE	REMEDY
Unit does not operate to dispense	Batteries polarity is wrong	Ensure correct position by diagram
	Batteries Voltage is too low (LED always ON)	Replace batteries with new batteries
	Dirt on lens blocking sensor	Clean lens (see section 6, adjacent)
	Sensor continuously false triggered	Remove object activating sensor
	Cover is not closed to engage switch	Close & lock cover
Unit operates, no soap is dispensed	Control module is not aligned straight	Ensure tracks & lock tab are engaged
	Soap reservoir is empty	Clean & refill reservoir
	Reservoir check valve is blocked	Clean tank & check valve & refill
LED does not indicate operation	Reservoir is not engaged in feed port	Insert check valve into soap feed port
	Dispense Nozzle is blocked	Clean nozzle
	LED circuit or component has failed	Replace Control Module (item 8)
LED flashes while unit is not operating	LED Light-pipe has been vandalized	Replace Light-pipe (item 5, above)
	Batteries Voltage is too low	Replace batteries with new batteries
Low volume soap dispense amount	Soap condition is improper	Ensure viscosity is within range
	User removed hands too early	Advise users to stay for full dispense
Unit operates to dispense with no hand	Bright light reflected from below	Change angle of spot light above
	Control Module has failed circuit	Replace Control Module (item 8)
Problems not listed above	Combinations of mysteries	Contact supplier for service

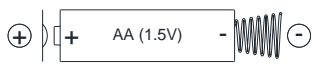
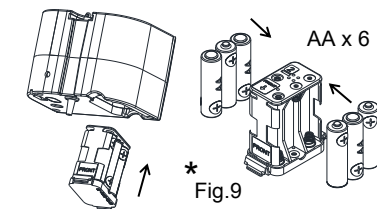
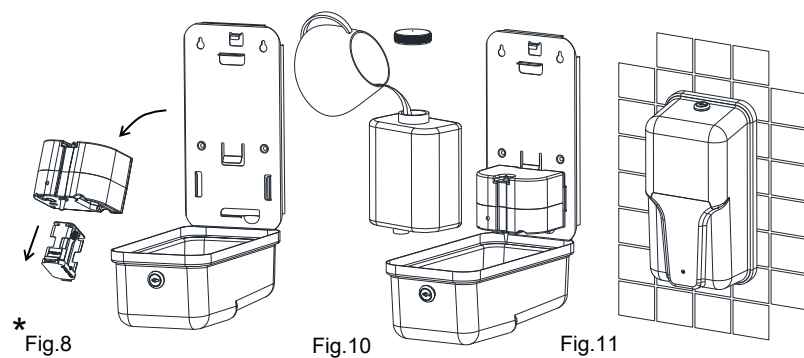

Fig.12