



A WATTS Brand

2B5 Series

Elvari™ Surface-Mounted Combination Unit

Key Features

- High quality and modern style complements other [Elvari™ products](#)
- Advanced weld construction
- Pill-shape design
- Bag retention ring included
- Concealed BradLock™ magnetic locking system

Operation

Towel dispenser holds C-fold or multi-fold towels with integral, easy-feed towel guide liner. Red, low-level indicator provides notice that refill is needed. Waste receptacle is removable for servicing by lifting the bag retention ring/handle. BradLock system and magnetic key on the towel dispenser provide security, a seamless design, and easy access for service. Magnetic lock location is hidden from view behind the Bradley logo.

Capacity

Small Capacity

- Towel Dispenser: Approximately 400 folded paper towels
- Waste Receptacle: 10 gallon

Medium Capacity

- Towel Dispenser: Approximately 500 folded paper towels
- Waste Receptacle: 14 gallon

Large Capacity

- Towel Dispenser: Approximately 800 folded paper towels
- Waste Receptacle: 18 gallon

Guide Specification

Surface-mounted towel and waste receptacle combination unit. High quality and style. 20-gauge, 300 series stainless steel in a brushed #3 satin finish or optional electrocoat finishes. Welded, pill-shape construction. Bag retention ring holds liners in place and can serve as a handle. 20-gauge stainless steel connecting plate protects walls and makes cleaning easier.

Overall Dimensions – Small Capacity:

32-1/4" H x 17" W x 13" D (819mm x 249mm x 330mm)

Overall Dimensions – Medium Capacity:

47-3/16" H x 17" W x 13" D (1198mm x 249mm x 330mm)

Overall Dimensions – Large Capacity:

59" H x 17" W x 13" D (1496mm x 249mm x 330mm)

MasterFormat Title: Commercial Toilet Accessories

MasterFormat Number: 10 28 13.13

OmniClass Title: Toilet and Bath Specialties

OmniClass Code: 23.31.25.00

For information on Warranties, Maintenance and BAA/ARRA Compliance, visit our website at: bradleycorp.com/washroom-accessories-products

Orders composed of products indicated as **BradEX®** will be available to ship in three days after receipt of order at the factory. There is no pricing penalty for this service from Bradley.

Verify all rough-in dimensions prior to installation.

Page 1 of 3

1/31/2024

[View Latest Version](#)

This information is subject to change without notice.
Bradley_CombiDispenser_2B5-Series



Model 2B5-110000 shown

Product Compliance

Complies with

- The Americans with Disabilities Act (ADA) 
- ANSI/ICC A117.1 - Accessible and Usable Buildings & Facilities

Listed by UL Environment to

- GreenGuard Gold



- Consult local and national accessibility codes for proper installation guidelines. Conformity and compliance with local and national codes is the responsibility of the installer.

Finishes

- Click on any color swatch to view as a larger image.

-  Brushed Black*
-  Brushed Brass*
-  Brushed Bronze*
-  Brushed Nickel*
-  Brushed Stainless*
-  Satin Stainless

*Electrocoat Finishes, see Optional Electrocoat Finishes section on page 2.

© 2024 Bradley

P.O. Box 309, Menomonee Falls, WI 53052-0309
800 BRADLEY (800 272 3539) +1 262 251 6000
bradleycorp.com









2B5 Series Elvari™ Surface-Mounted Combination Unit

Optional Electrocoat Finishes

Bradley offers an exclusive, proprietary electrocoat color process on the Elvari combination unit models. Unlike powder coating, color is applied to the entire stainless steel part using a submersion process with electrically charged particles. This process results in a precise film thickness across all surfaces, allowing the grain of the stainless steel to show through.

Electrocoat provides complete coverage to the part and has environmental advantages such as no or low-VOC and HAPs (Hazardous Air Pollutants), heavy metal-free products, and minimum waste discharge. Bradley's electrocoat is durable and easy to clean as well as fingerprint, stain and corrosion resistant. A UV light stabilizer additive enhances resistance to weathering and color fade. Products are performance tested for adhesion following ASTM D3359-22 and impact resistance following ASTM D2794.

Model (Must select one)	
2B5	Elvari Combi Unit
Standard Selections (Must select one from each category)	
Mounting Type (select one)	
11	Surface Mounted
Towel & Waste Capacity (select one)	
34	Small Capacity
0	Medium Capacity ¹
36	Large Capacity
Combination Unit Finish Type (Must select one)	
BB	 Brushed Black
BR	 Brushed Brass
BZ	 Brushed Bronze
BN	 Brushed Nickel
BS	 Brushed Stainless
SS	 Satin Stainless ¹

¹ Model available with **BradEX**® expedited shipping.

Orders composed of products indicated as **BradEX**® will be available to ship in three days after receipt of order at the factory. There is no pricing penalty for this service from Bradley.

Verify all rough-in dimensions prior to installation.

Page 2 of 3
1/31/2024
This information is subject to change without notice.
Bradley_CombiDispenser_2B5-Series

[View Latest Version](#)

© 2024 Bradley
P.O. Box 309, Menomonee Falls, WI 53052-0309
800 BRADLEY (800 272 3539) +1 262 251 6000
bradleycorp.com



A WATTS Brand

2B5 Series Elvari™ Surface-Mounted Combination Unit

Dimensions

(mm)

Small Capacity

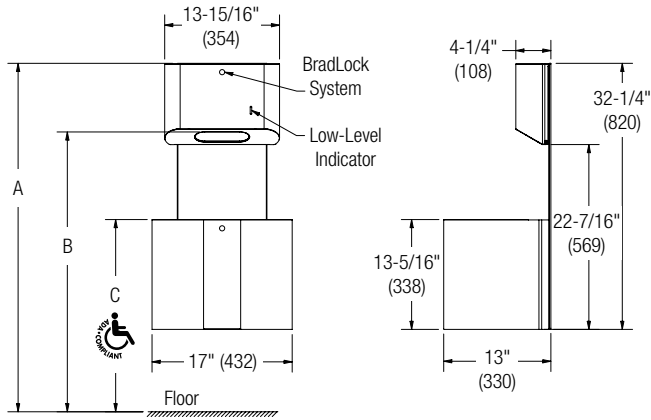

Medium Capacity

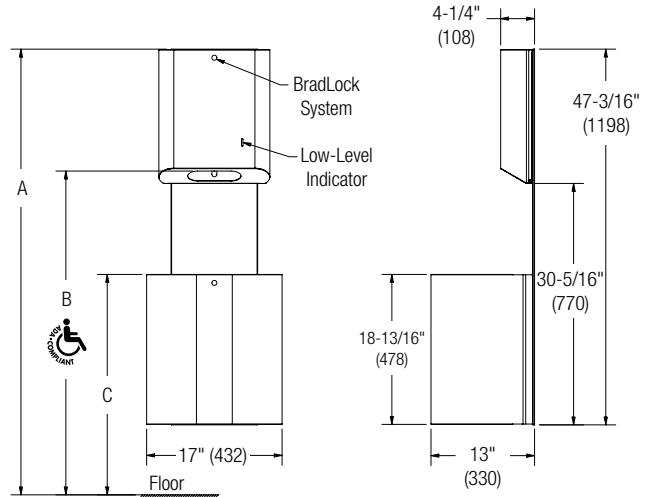

Large Capacity

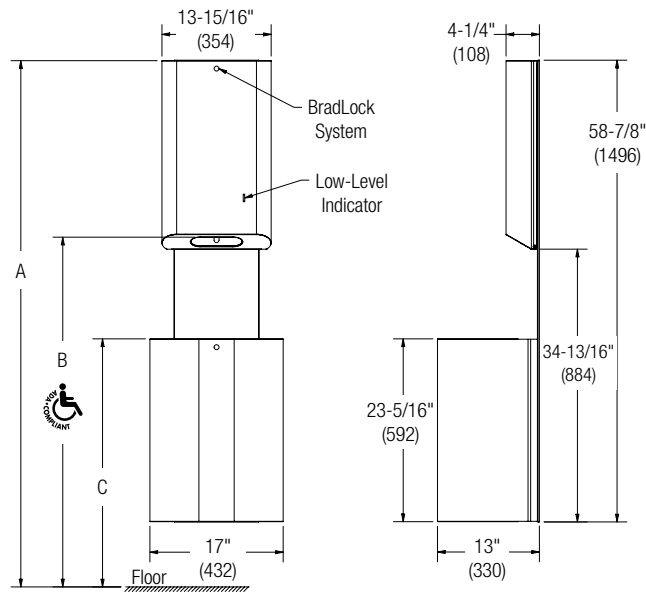

Combination Unit Capacity	Dim "A" (mm)	Dim "B" (mm)	Dim "C" (mm)
Small	55" (1397)	48-5/8" (1185)	36" ¹ (915)
Medium	63-3/8" (1609)	48" ¹ (1219)	35" (889)
Large	70-5/8" (1793)	48" ¹ (1219)	35" (889)

¹ ADA compliant

Orders composed of products indicated as **BradEX**® will be available to ship in three days after receipt of order at the factory. There is no pricing penalty for this service from Bradley.

Verify all rough-in dimensions prior to installation.