

Installation and Maintenance Guide

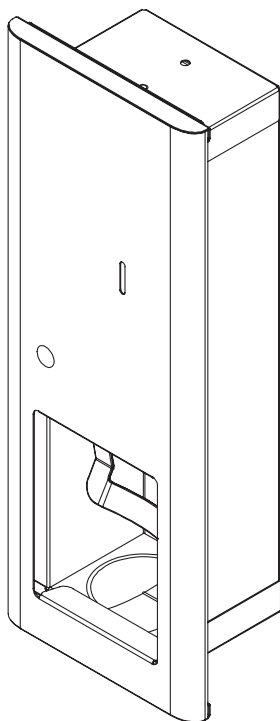

Elvari™ Recessed Soap Dispenser (Manual)

6B1 Series

Table of Contents

Safety Information	2
Dimensions.....	2
Installing the Soap Dispenser	3
Soap Dispenser Operation.....	4
Cleaning and Maintenance.....	4



[Scan or click code to view Installation Guide \(English\)](#)



[Scan or click code to view Installation Guide \(French\)](#)



[Scan or click code to view Installation Guide \(Spanish\)](#)



Read the instructions in this manual before beginning installation. Save these instructions and refer to them for inspection, maintenance, and troubleshooting information.

For questions regarding the operation, installation or maintenance of this product, visit bradleycorp.com or call 800.BRADLEY (800.272.3539). Product warranties and parts information may also be found under "Resources" on our website at bradleycorp.com.



Safety Information

WARNING

The soap dispenser assembly is no stronger than the anchors and walls to which it is attached, and therefore, must be firmly secured in order to support meet regulatory requirements. To avoid potential injury, the building owner or maintenance personnel should remove the dispenser assembly from service if the mounting is not adequately secured to the wall or if there are any observed product defects.

IMPORTANT

Read this entire installation manual to ensure proper installation. When installation is complete, file this manual with the owner or maintenance department. Compliance and conformity to local codes and ordinances is the responsibility of the installer.

Separate parts from packaging and make sure all parts are accounted for before discarding any packaging material. If any parts are missing, do not begin installation until you obtain the missing parts.

Dimensions

(mm)

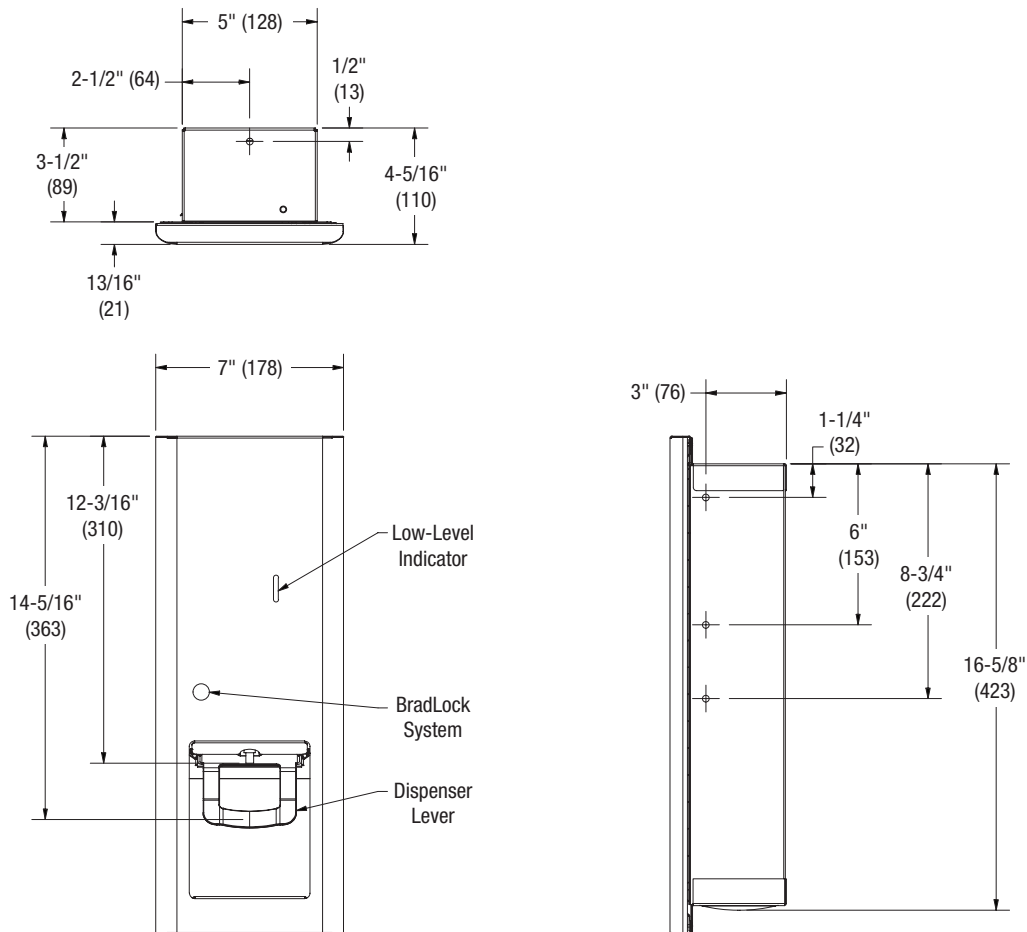

Installing the Soap Dispenser



Coordinate installation with architect and contractor to avoid protrusion from opposite wall or pipes, vents, conduits, electrical wiring, etc., in wall.

Follow all applicable local building codes. If installing where unit projects above top of wainscot, provide aluminum channel or other filler to prevent gap from finished wall and flange of unit. For block walls, use metal expansion shields (not included).

A

Prepare the wall opening to the size shown in the illustration. Verify the opening has proper backing for fasteners being used (supplied by installer).

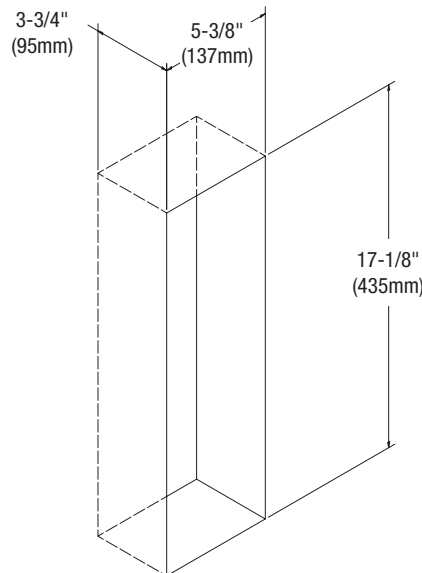

B

Open the dispenser cover.

1. Place the magnetic key (included) on the Bradley logo and slightly push to disengage the lock.
2. With the magnetic key still on the logo, open the dispenser door.
3. Leave the magnetic key on the Bradley logo.

C

Remove the soap tank/pump from the dispenser by sliding forward until they stop. Then tilt the tank/pump upwards until both can be pulled forward out of the dispenser.

D

Place the dispenser inside of the wall opening and position as close to the hinge side as possible.



It is important to position the dispenser as such to create clearance on the latch side, allowing the latch to properly function.

E

Insert fasteners through the mounting holes on the hinge side first, and then insert fasteners through the mounting holes on the latch side.

F

Install the soap tank and soap pump into the dispenser.

G

With the magnetic key still on the logo, gently close the dispenser door. Remove the magnetic key.

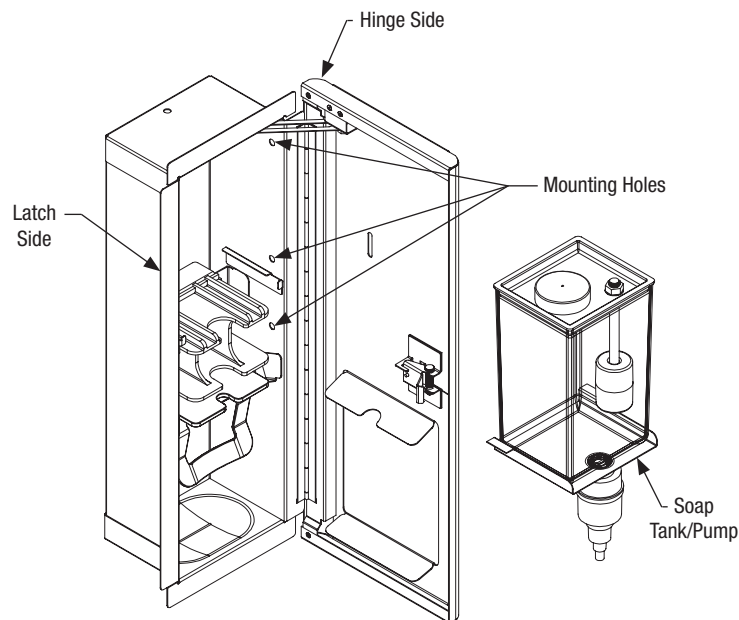

Soap Dispenser Operation

Refilling the Soap Tank

1. Slide the soap tank (with pump attached) forward, remove the cap, and refill with soap.
2. Reattach the cap and ensure the air vent hole is open and the pump nozzle is not clogged.
3. Verify the outside of the soap tank is clean and that there are no leaks.
4. Reinstall the soap tank into the dispenser. Verify the pump is properly seated in the control box.

Cleaning and Maintenance

Cleaning Soap Dispenser Components

The soap tank, cap, level indication assembly, and soap pump require periodic cleaning to maintain proper function.

- Unlock and open the dispenser cover and then remove the components from the dispenser.
- Rinse the soap tank, cap, and level indication assembly using warm water.
- Add hot water to the soap tank (with the pump attached) and then activate the pump a minimum of 20 times to flush any hardened soap residue from the inside of the pump.

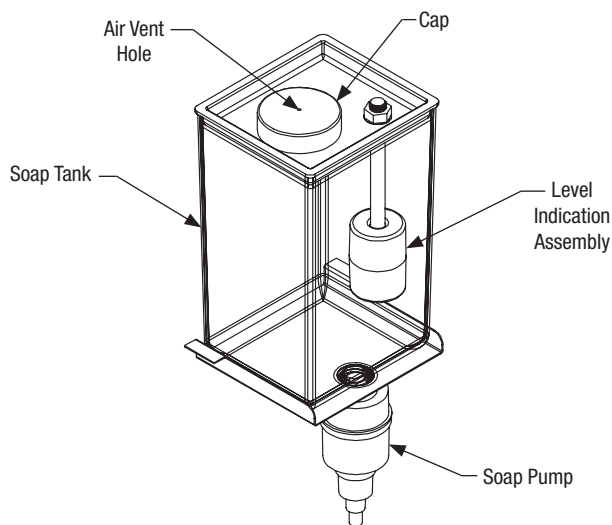

Cleaning Stainless Steel

Scan or click the QR code below to view the Stainless Steel Washroom Accessories document.

