

Installation and Maintenance Guide

Elvari™ Surface-Mounted Soap Dispenser (Sensored)

6B1 Series

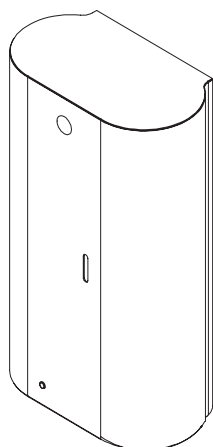

Sensored Soap Dispenser

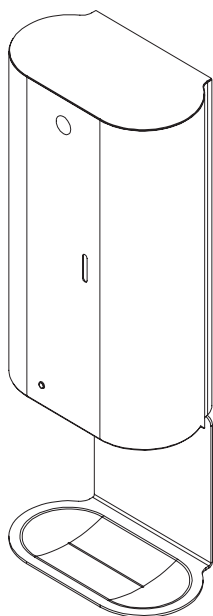

Sensored Soap Dispenser with Optional Drip Tray

Table of Contents

Safety Information	2
Dimensions.....	2
Installing the Soap Dispenser	3
Soap Dispenser Operation.....	4
Cleaning and Maintenance.....	5



[Scan or click code to view Installation Guide \(English\)](#)



[Scan or click code to view Installation Guide \(French\)](#)



[Scan or click code to view Installation Guide \(Spanish\)](#)



Read the instructions in this manual before beginning installation. Save these instructions and refer to them for operation and maintenance information.

For questions regarding the operation, installation, or maintenance of this product, visit bradleycorp.com or call 800.BRADLEY (800.272.3539). Product warranties and parts information may also be found under “Resources” on our website at bradleycorp.com.



Safety Information

WARNING

The soap dispenser assembly is no stronger than the anchors and walls to which it is attached, and therefore, must be firmly secured in order to support meet regulatory requirements. To avoid potential injury, the building owner or maintenance personnel should remove the dispenser assembly from service if the mounting is not adequately secured to the wall or if there are any observed product defects.

IMPORTANT

Read this entire installation manual to ensure proper installation. When installation is complete, file this manual with the owner or maintenance department. Compliance and conformity to local codes and ordinances is the responsibility of the installer.

Separate parts from packaging and make sure all parts are accounted for before discarding any packaging material. If any parts are missing, do not begin installation until you obtain the missing parts.

Dimensions

(mm)

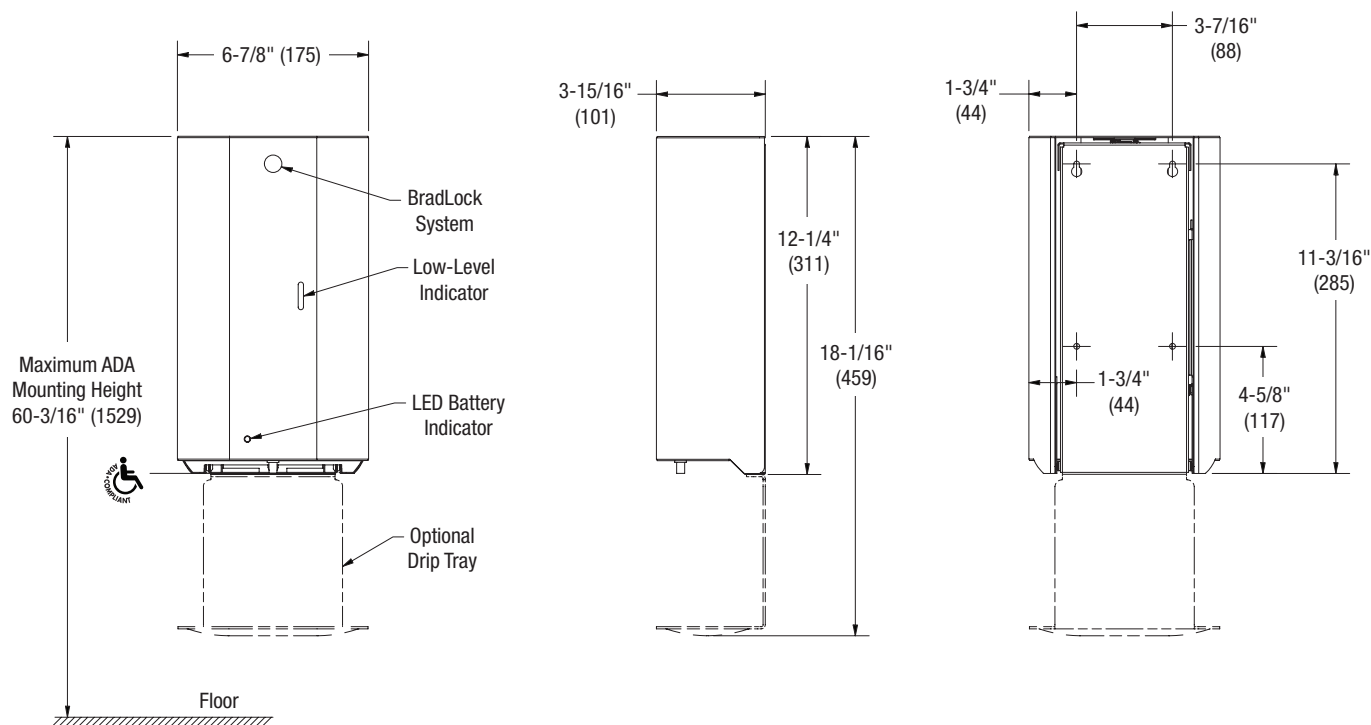

Installing the Soap Dispenser



Coordinate installation with architect and contractor to avoid protrusion from opposite wall or pipes, vents, conduits, electrical wiring, etc., in wall.

Follow all applicable local building codes. If installing where unit projects above top of wainscot, provide aluminum channel or other filler to prevent gap from finished wall and flange of unit. For block walls, use metal expansion shields (not included).

A Mark the four mounting holes as shown in the illustration on page 2.

B Drill the holes and set the anchors (not included).

C Insert two screws into the top mounting holes. Be sure to leave a small gap between the fastener heads and the mounting surface.

Open the dispenser cover.

D

1. Place the magnetic key (included) on the Bradley logo and slightly push to disengage the lock.
2. With the magnetic key still on the logo, pull the cover slightly to open the dispenser.
3. Leave the magnetic key on the Bradley logo.

E Remove the soap tank and soap pump from the dispenser and then fully tighten the top fasteners to the dispenser back plate.

F Insert screws into the bottom mounting holes and then fully tighten.

G Install soap tank and soap pump back into the dispenser.

H With the magnetic key still on the logo, lift the cover and close. Remove the magnetic key.



Verify the type of soap being used (foam, liquid, etc.) is compatible with the dispenser. Compatible soap types can be found on the soap pump.



For units without a drip tray and mounted over a counter or sink, verify the minimum distance between the bottom of the dispenser and countertop (minimum distance listed below).

Non-reflective countertop: 7-7/8" (200mm)

Metal/Reflective countertop: 11-13/16" (300mm)

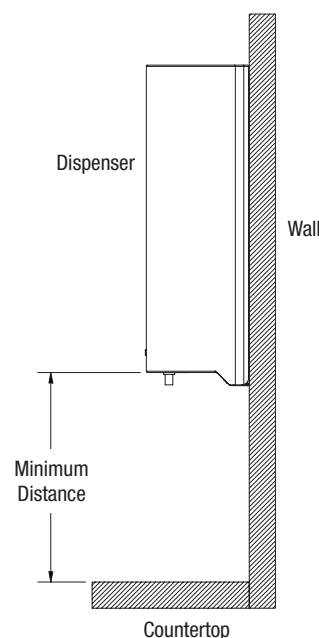
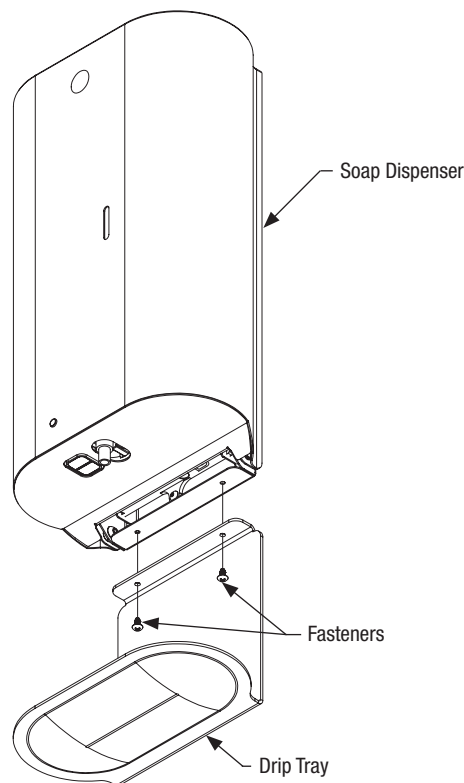

Soap Dispenser Operation

Installing Batteries

1. Use the magnetic key to open the dispenser door.
2. Open the battery compartment door and then remove the battery box and unplug the cable.
3. Install 4 new alkaline Type AA 1.5V batteries with the correct polarity to obtain 6V DC \pm 10% at the plug.

Note: Batteries installed with the incorrect polarity may cause malfunction.

4. Reinstall the battery box and close the battery compartment door.

Refilling the Soap Tank

1. Remove the soap tank (with pump attached), remove the cap, and refill with soap.
2. Reattach the cap and ensure the air vent hole is open and the pump nozzle is not clogged.
3. Verify the outside of the soap tank is clean and that there are no leaks.
4. Reinstall the soap tank into the dispenser. Verify the pump is properly seated in the control box.

Soap Tank Operation

1. Close the dispenser door.
2. Verify the LED light is blue and flashes 4 times, indicating that the environment has been detected.
 - If there is an object (basin, counter, etc.) below the dispenser, the sensor will detect the installation height and environment light to set a suitable sensing distance automatically.
 - If there is no object under the dispenser, the default sensing distance is 3.15" to 3.93" (80mm to 100mm).
3. Trigger the sensor using your hand or a towel to ensure a proper soap dispensing cycle.
4. Adjust as needed.

⚠ CAUTION Do not immerse the soap dispenser in water or clean it under running water. This will cause the dispenser to short circuit.

⚠ CAUTION Do not attempt to repair a dispenser that is not in working order. Remove the dispenser from service and contact Bradley support.

NOTICE! Ensure no bright light source is aimed or reflected at the sensor from below to help prevent false activation from occurring.

Battery Low Indication

With the dispenser cover open and the soap tank and soap pump removed, conduct a diagnostics test.

1. Close the dispenser cover and hold it in place.
2. Verify the LED light is blue and flashes 4 times, indicating Standby Mode and battery charge level. If the LED light continues to flash blue, this indicates the batteries need to be replaced.

Cleaning and Maintenance

Cleaning Soap Dispenser Components

The soap tank, cap, level indication assembly, and soap pump require periodic cleaning to maintain proper function.

- Unlock and open the dispenser cover and then remove the components from the dispenser.
- Rinse the soap tank, cap, and level indication assembly using warm water.
- Add hot water to the soap tank (with the pump attached) and then activate the pump a minimum of 20 times to flush any hardened soap residue from the inside of the pump.

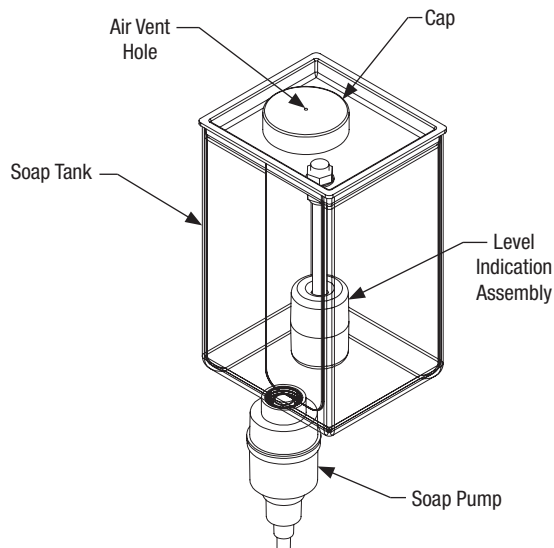

Cleaning Stainless Steel

Scan or click the QR code below to view the Stainless Steel Washroom Accessories document.

