



8111835

EXP'AIR automatic black 115V



Exp'air automatic black hand dryer with forced air. Anti-vandalism with aluminum hood and adapted to people with reduced mobility. Equipped with a water recovery tank or a direct evacuation solution. 3 years warranty.

PRODUCT ADVANTAGES

- 35% more economical than competitors' models
- 50% quieter than competitors' models
- 100% accessible by people with reduced mobility and small children

10 YEARS REPAIRABLE



MADE IN FRANCE



8111835



EXP'AIR automatic black 115V

SPECIFICATIONS

Material	Aluminum
Colour	Black
Water tray	Yes
Water tray capacity (oz)	0.0338
Drain connection	No
Drying time (s)	10-15
Sound level (dB) (1m in front of the appliance)	75
Outlet air speed (m/s)	600
Air flow rate (m³/h)	140
Air outlet temperature (°F)	104
Safety in case of malfunction	Yes
Filter	Copper filter
Vandal-safe	Yes
Antibacterial treatment	Yes

ELECTRICAL

Rated Power (W)	1000
Voltage	110_120V
Frequency (Hz)	60
Detection type	Capacitive
Motor speed (rpm)	26500
Type of motor	Brushed AC
Motor lifetime (number of operations)	350000

DIMENSIONS

Height (in.)	16.93
Width (in.)	13.50
Depth (in.)	9.33
Weight (lbs)	13.23

BOX DIMENSIONS

Height (in.)	13.39
Width (in.)	14.17
Depth (in.)	19.39
Weight (lbs)	17.64

TECHNICAL DRAWING

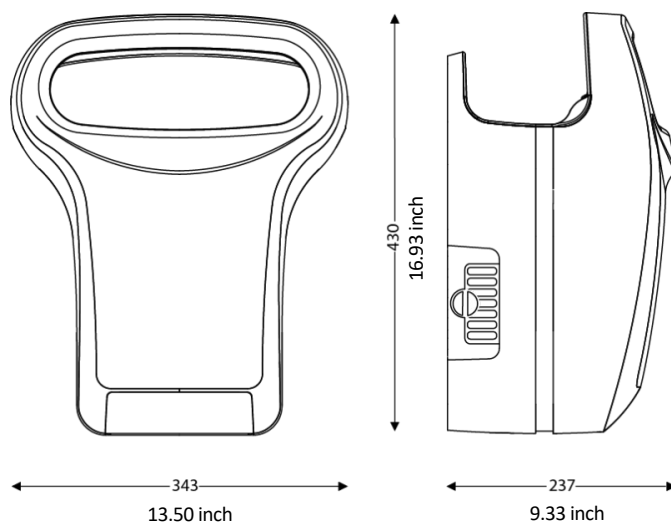

RECOMMENDED INSTALLATION HEIGHTS

- Men installation height (in.) : 29.53
- Women installation height (in.) : 25.59
- Children installation height (in.) : 21.65
- Disabled person installation height (in.) : 25.59

